

# FLANGE A SALDARE DI TESTA SCH.160

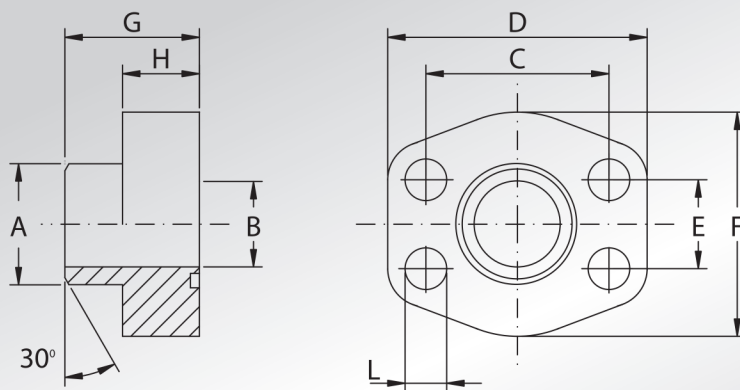

## WELD ON FLANGES SCH.160



Pressione max di esercizio raccomandata Kg/cm <sup>2</sup>	Grandezza	Tipo	Dimensioni									Viti		Or tipo	Peso Kg
Maximum recommended working pressure Kg/cm <sup>2</sup>	Size	Type	Dimensions									Screws		Or type	Weight Kg
			A	B	C	D	E	F	G	H	L	Metric	Unc		

### SERIE 3000

345	1/2"	AFS080STB11	21,5	11,8	38,10	57	17,48	46	36	16	9	M8x30	5/16"x1"1/4	4075	0,24
345	3/4"	AFS100STB15	28,0	15,6	47,63	65	22,23	50	36	18	11	M10x35	3/8"x1"1/2	4100	0,35
345	1"	AFS102STB20	34,0	20,7	52,37	70	26,19	55	38	18	11	M10x35	3/8"x1"1/2	4131	0,41
276	1"1/4	AFS104STB29	42,8	29,5	58,72	79	30,18	68	41	21	11,5	M10x40	7/16"x1"3/4	4150	0,64
207	1"1/2	AFS106STB34	48,6	34	69,85	93	35,71	78	44	25	13,5	M12x45	1/2"x1"3/4	4187	0,98
207	2"	AFS108STB42	61,0	42,8	77,77	102	42,88	90	45	25	13,5	M12x45	1/2"x1"3/4	4225	1,14
172	2"1/2	AFS110STB54	77,0	54	88,90	114	50,80	105	50	25	13,5	M12x45	1/2"x1"3/4	4275	1,55
138	3"	AFS112STB67	92,0	67,7	106,38	134	61,93	124	50	27	17,5	M16x50	5/8"x2"	4337	2,33
138	4"	AFS116STB87	115,5	87,3	130,18	162	77,77	146	48	27	17,5	M16x50	5/8"x2"	4437	2,85
138	5"	AFS118STB109	140,2	109,5	152,40	184	92,08	180	50	28	17,5	M16x55	5/8"x2"1/4	4537	5,20

### SERIE 6000

414	1/2"	AFS401ST012B11	21,5	11,8	40,49	57	18,24	46	36	16	9	M8x30	5/16"x1"1/4	4075	0,24
414	3/4"	AFS402STB15	28,0	15,6	50,80	71	23,80	55	35	21	11	M10x40	3/8"x1"1/2	4100	0,48
414	1"	AFS403STB20	34,0	20,7	57,15	79	27,76	68	42	25	13	M12x45	7/16"x1"3/4	4131	0,64
414	1"1/4	AFS404STB29	42,8	29,5	66,68	93	31,75	78	44	25	15	M14x45	-	4150	1,00
414	1"1/4	AFS404STB29 L13	42,8	29,5	66,68	93	31,75	78	44	25	13,5	M12x45	1/2"x1"3/4	4150	1,00
414	1"1/2	AFS405STB34	48,6	34	79,38	112	36,50	94	55	28	17	M16x55	5/8"x2"1/4	4187	1,68
414	2"	AFS406STB42	61,0	42,8	96,82	134	44,45	114	65	37	21	M20x70	3/4"x2"3/4	4225	2,86
350	2"1/2	AFS507STB54 *	76,6	54	123,80	180	58,70	152	80	45	26	M24x80	7/8"x3"1/4	4275	7,20
350	3"	AFS508STB67 *	90,0	67,7	152,40	208	71,40	178	90	55	33	M30x100	1"1/8"x3"1/2	4337	11,25

PER QUESTA TIPOLOGIA DI PRODOTTO, VERIFICATE SEMPRE SE LA QUOTA "A" E "B" CORRISPONDE ALLA SCHEDULA DEL VOSTRO TUBO

FOR THIS KIND OF PRODUCT, PLEASE ALWAYS VERIFY IF DIMENSION "A" AND "B" CORRESPOND TO THE SCHEDULE OF YOUR TUBE

DESIGNAZIONE PER ORDINE DESIGNATION FOR ORDER	Materiale / Material	
	S355	AISI 316L
Solo flangia Only flange	<b>AFS...STB</b>	<b>AFX...STB</b>
Flangia completa di viti metriche, grower e o-ring Flange complete of metric screws, grower type washers and o-ring	<b>AFS...STB...M</b>	<b>AFX...STB...M</b>
Flangia completa di viti unc, grower e o-ring Flange complete of unc screws, grower type washers and o-ring	<b>AFS...STB...U</b>	<b>AFX...STB...U</b>

#### NOTE / NOTES

set viti unc disponibili solo in acciaio al carbonio  
unc screws set available only in carbon steel

\*set viti disponibili solo metriche in acciaio al carbonio  
\*screws set available only metric in carbon steel